

~~1s~~
~~2s 2p~~
~~3s 3p 3d~~
~~4s 4p 4d 4f~~
~~5s 5p 5d 5f ...~~
~~6s 6p 6d ...~~
~~7s 7p ...~~
~~8s ...~~

Increasing Energy

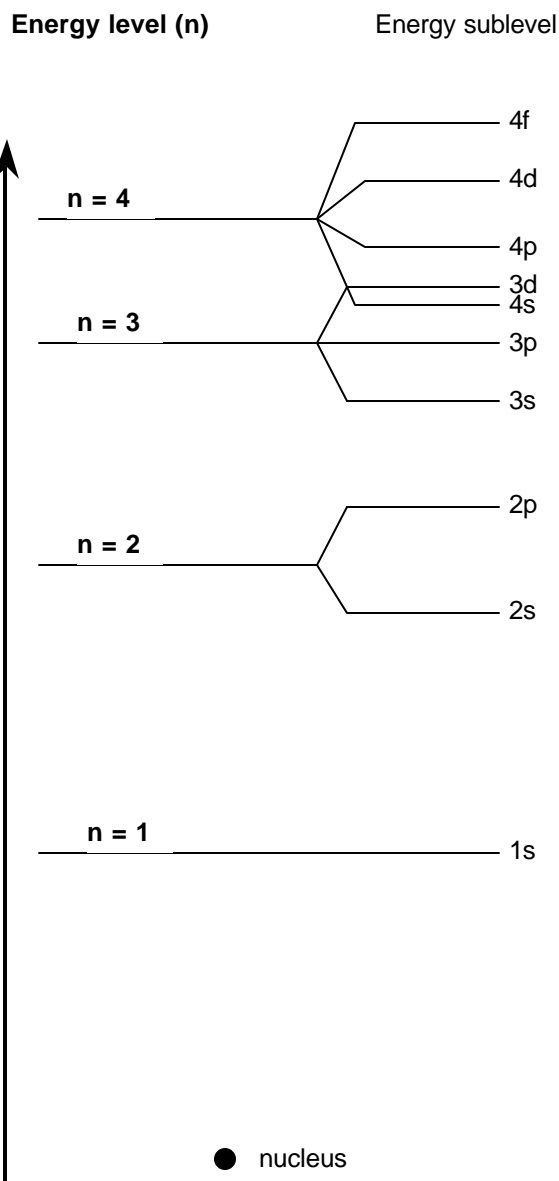

The order of increasing energy of the sublevels:

1s 2s 2p 3s 3p 4s 3d 4p 5s 4d 5p 6s 4f 5d 6p 7s 5f 6d ...

This order corresponds to the order in which the energy sublevels are filled by electrons.