

Carnot Refrigeration Cycle

- Reverse the Carnot Power Cycle

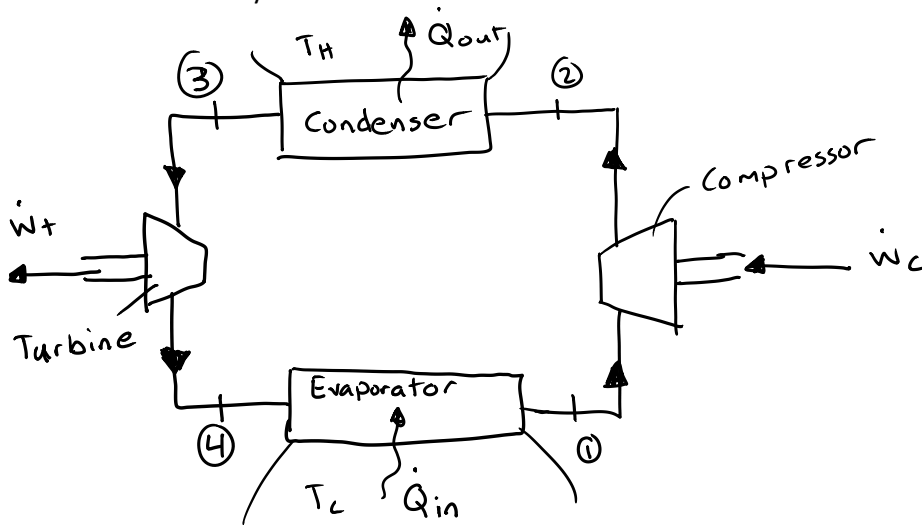

Vapor Compression Refrigeration Cycle

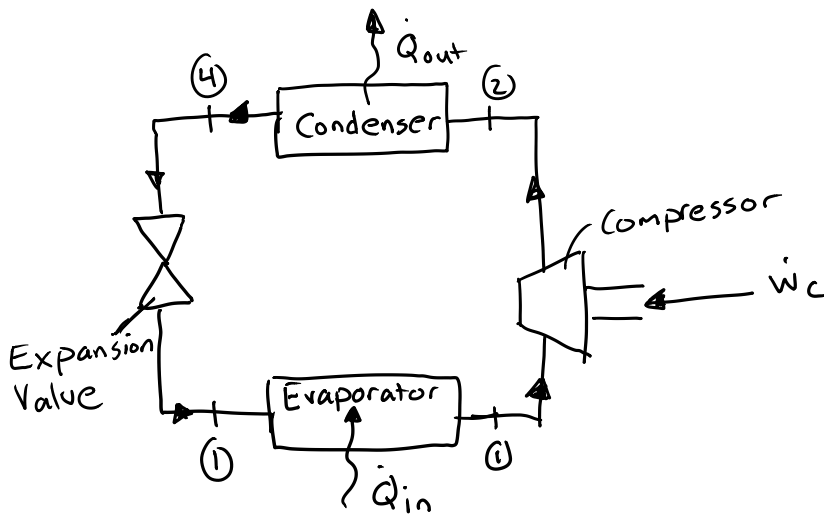

Ideal Vapor Compression Cycle

- All processes are internally reversible except 3-4

Process 1-2

- Compressor
- Isentropic compression from saturated vapor to superheated vapor

$$0 = \dot{Q}_{cv} - \dot{w}_{cv} + \dot{m}(h_1 - h_2)$$

$$\dot{w}_{cv} = -\dot{w}_c$$

$$\boxed{\frac{\dot{w}_c}{\dot{m}} = h_2 - h_1}$$

Process 2-3

- Condenser
- Heat transfer from the refrigerant to saturated liquid at constant pressure

$$0 = \dot{Q}_{cv} - \dot{w}_{cv} + \dot{m}(h_2 - h_3)$$

$$\boxed{\frac{\dot{Q}_{out}}{\dot{m}} = h_2 - h_3}$$

Process 3-4

- Expansion Valve
- Throttling process to a two-phase liquid-vapor mixture

$$0 = \dot{Q}_{cv} - \dot{w}_{cv} + \dot{m}(h_3 - h_4)$$

$$\boxed{h_4 = h_3}$$

Process 4-1

- Evaporator
- Heat transfer to the refrigerant at constant pressure

$$0 = \dot{Q}_{cv} - \dot{w}_{cv} + \dot{m}(h_4 - h_1)$$

$$\dot{Q}_{cv} = \dot{Q}_{in}$$

$$\boxed{\frac{\dot{Q}_{in}}{\dot{m}} = h_1 - h_4}$$

Coefficient of Performance

$$\beta = \frac{\dot{Q}_{in}/\dot{m}}{\dot{w}_c/\dot{m}}$$

Units

1 ton of refrigeration = 200 Btu/min = 211 kJ/min